

# spinifex®

## NAKARA 3V TENT 90133431



### Before you begin

Thank you for purchasing this quality Spinifex product. Please keep these instructions handy as it contains important and helpful information.

- Read all instructions before set up.
- Select a level site clear of rocks, branches, and other hard or sharp objects, to install your tent.
- Do not set up your tent under trees because of potential lightning strikes or falling tree limbs in inclement weather.
- **NOTICE: Ensure product is secured with all tent pegs, guy ropes and fly attachments for optimal performance and to prevent property damage or personal injury.**
- For best results in windy conditions, position narrow end of tent into the wind. This tent is not designed to withstand storm conditions. During strong winds, it is recommended that the tent be taken down.
- Two people recommended for setup.

### Things You Should Know

- Condensation is normal and IS NOT LEAKAGE. It can be minimised by providing good ventilation.
- Tree limbs, tree sap, bird droppings, or moisture steadily dripping off tree limbs can cause damage to the tent fabric and its coating. Do not pack away tent without drying it off thoroughly and brushing off caked dirt. If mildew does form on your tent wash off with warm water and a soft brush to prevent further growth. Do not use detergents.
- Ensure all guy ropes are pegged out and tensioned correctly at all times during use.
- Do not leave your tent pitched unnecessarily for extended periods of time. UV light damages the fly fabric and will shorten the life of your tent
- Pegs should be removed by pulling on the peg itself. NEVER PULL ON THE TENT TO REMOVE tent pegs AS THIS COULD RESULT IN PROPERTY DAMAGE OR PERSONAL INJURY.

PLEASE NOTE: Due to our policy of continual product development specifications, parts and features may vary from details within this owners manual.

### WARRANTY

This product is guaranteed to be free from defects in workmanship & materials for a period of 12 months from date of purchase.

The product will be repaired or replaced at our discretion should the product fail to be of an acceptable quality and failure is not a major failure.

Warranty will not apply if the product (a) is damaged through misuse (including failure to maintain), neglect, accident or ordinary wear & tear (including rust, corrosion & normal fading, weathering, staining, discolouration, scratching or chipping); (b) is damaged through exposure to heat; (c) is used commercially; (d) has not been used or installed in accordance with any applicable instruction; or (e) has been modified, repaired or tampered with by the purchaser or an unauthorised service person.

Our goods come with guarantees that cannot be excluded under the Australian Consumer Law. You are entitled to a replacement or refund for a major failure and for compensation for any other reasonably foreseeable loss or damage. You are also entitled to have the goods repaired or replaced if the goods fail to be of acceptable quality and the failure does not amount to a major failure.

To claim under this warranty, take this product to any Anaconda store where you purchased it. You will need your receipt or other proof of purchase. Additional information may be requested of you to process your claim. Should you not be able to provide proof of purchase with a receipt, a bank or credit card statement, and identification showing your name, address and signature may be required to process your claim. Any expense relating to the return of the product to the store will be at the cost of the customer. For online purchases, please contact us to arrange where and how to return the product.

To obtain compensation, you would need to provide documentary evidence of the loss or damage suffered, and documentary evidence that such loss or damage was a reasonably foreseeable consequence of a failure. Such evidence may include photographs, statutory declarations, receipts, reports (e.g. from your doctor), depending on the loss or damage.

The benefits given by this warranty are in addition to other right and remedies under the Australian Consumer Law in relation to the goods and services to which this warranty relates.

Warranty excludes consumable replacement/serviceable parts (where applicable to the product) such as injectors (Jets), "O" rings, lantern glasses, mantles, wicks, batteries, bulbs, etc as detailed in the product Instruction manual or packaging which are available for purchase.

This warranty is provided by  
Anaconda Group Pty Ltd (ABN 53 955 173 782). Level Six, 111 Cecil Street  
South Melbourne VIC 3205  
[www.anaconda.com.au](http://www.anaconda.com.au)  
Ph: 1300 558 990

# spinifex®

## HOW TO SET UP AND DISASSEMBLE

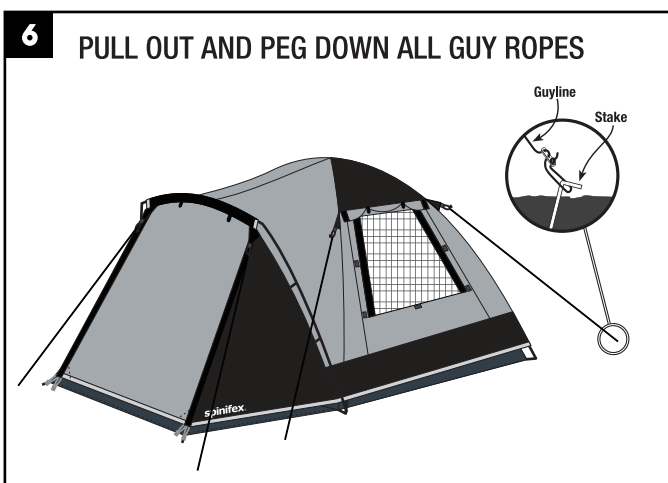
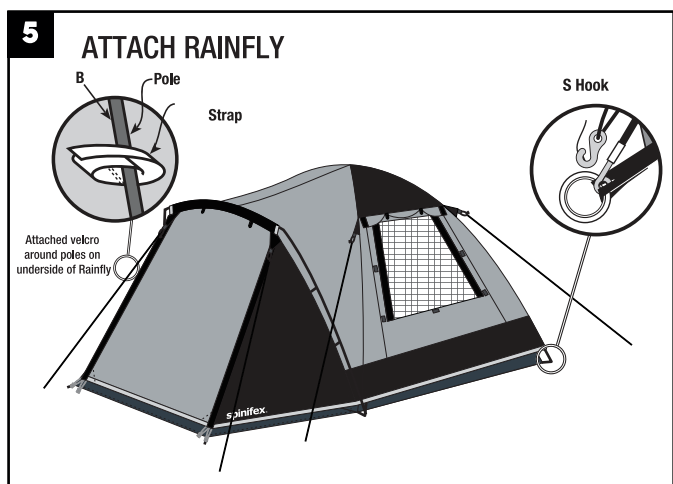
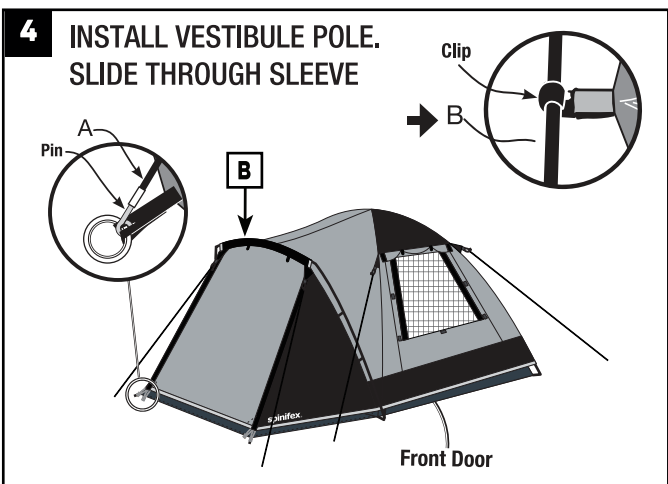
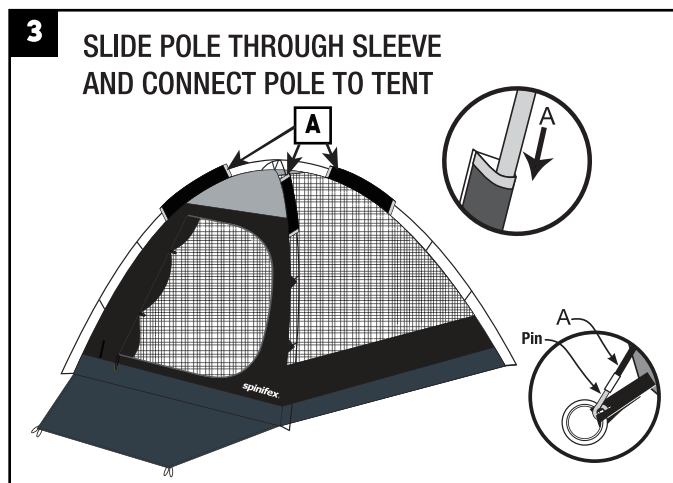
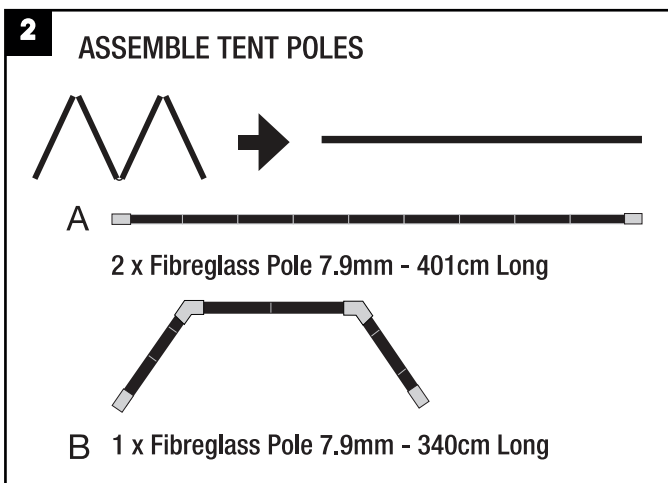
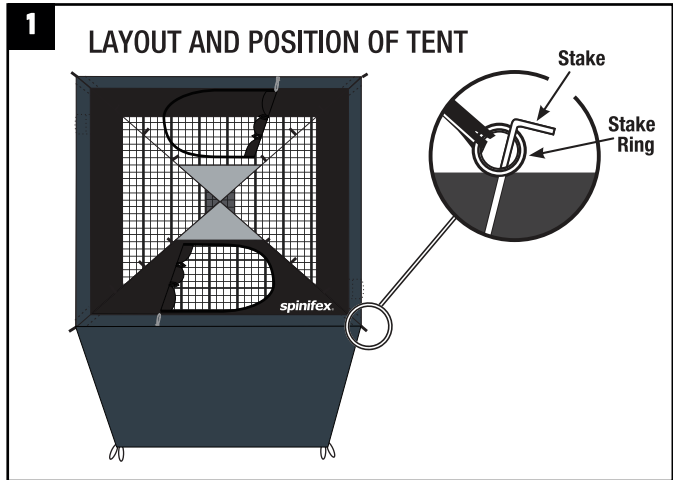

### DISASSEMBLY

To take down the tent, follow the previous steps and illustrations in the reverse order.

### HOW TO STORE

