

**DUNE 4WD NOMAD DELUXE  
HARDTOP ROOFTOP TENT 140CM**

**INSTRUCTION MANUAL**

# CONTENTS

Before using this product, please follow the instruction manual to ensure proper use.

## Products Brief Instruction:

1.Product Brief Instruction-----	1
2.Product Specification-----	1
3.Product Frame-----	1

## Installation

1.Installing Your Roof Tent-----	2
2.Setting up-----	5
3.Folding down-----	7

Malfunction and Solution-----	8
-------------------------------	---

## Product description :

This semi-auto roof top tent could be set up easily by 2 persons, set up and fold down in seconds with patented gas strut assisted opening mechanism. Enjoy the outdoor life in whatever weather !

## Material and specification :

- A. The whole frame uses aluminium alloy parts whilst using strong 100% virgin nylon.
- B. Heavy duty tent material and all seam taped for great waterproof.
- C. Good quality 50mm foam mattress provides comfortable sleep experience.
- D. Telescopic aluminium alloy ladder is removable and endure 150kg
- E. Tent fully opened dimensions: 205x139x100cm
- F. Tent closed dimensions: 221x155x25cm
- G. Net Weight: 75kg (ladder not included) Gross Weight: 94 kg

## Product frame :

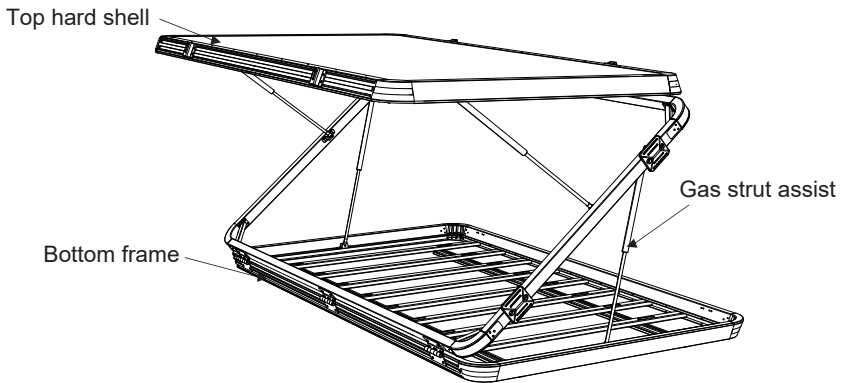

## Installation:

Two detachable roof bars can be installed horizontally or vertically on shell as needed. Please install the bars on the shell before mounting tent on car roof.

- ① Insert fixed parts of bar into slot of frame on both side.
- ② Adjust the height of bar then screw tightly with M8x15mm Hex Bolt, M8 Flat Washer and M8 Arc Washer.

M8 Arc Washer

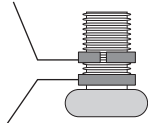

M8 Flat Washer

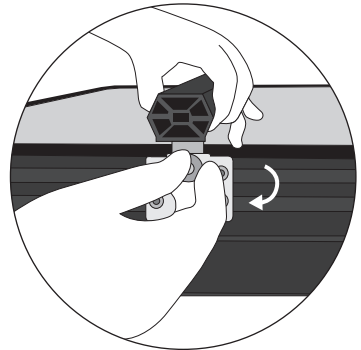
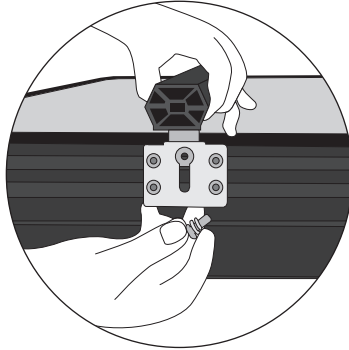

- ③ If install vertically, use Hex Wrench adjust the direction of fixed parts of bar as below, then follow step 1 and 2.

Horizontal direction

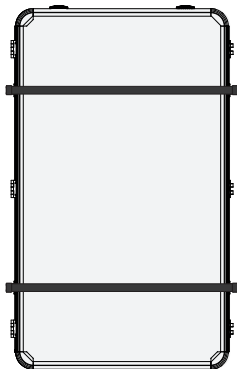
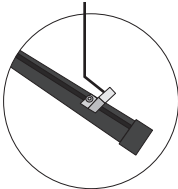

Horizontal installation

Vertical direction

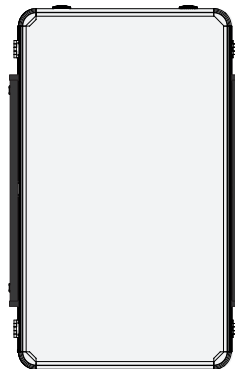
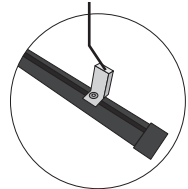

Vertical installation



**Note:** Please make sure nothing loaded on the top shell when opening/closing the tent.

# Installation:

1. Install your roof rack per the manufacturers instructions and in the load bearing position on the vehicle.

2. Lift up the tent onto the rack from car side. Adjust the tent to the roof center, ensuring the rear door can be opened/closed.

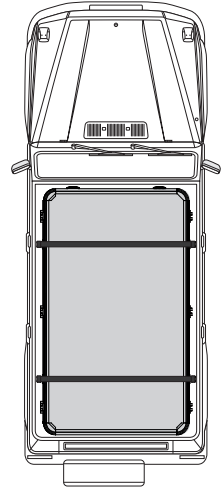
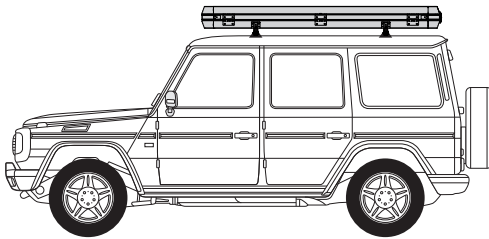

3. Slide the T Shape Bolts into the rails from two sides(as P1).

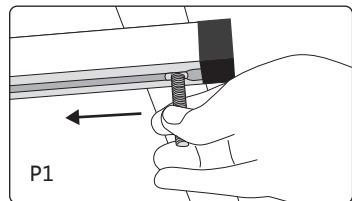

4. Slide T Shape Bolts into the middle hole of rail, with U-Shape Stator, M8 Arc Washer, M8 Flat Washer, and Plastic Nut lightly screwed in advance.(as P2)

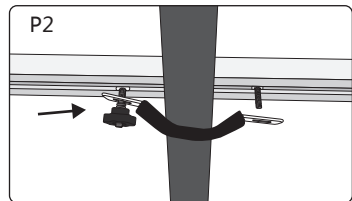

M8 Arc Washer

M8 Flat Washer

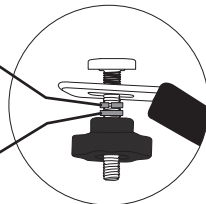

5. Screw the other side of U Shaped Stator with component in order as above, and ensure Stator tightened(as P3, same operation for rest).

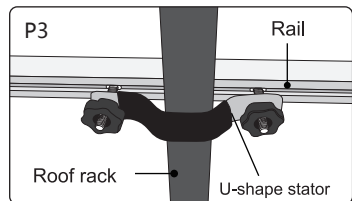

# INCLUDED TOOLS:



U Shape Stator(4pcs)

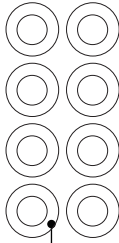

M8 Flat Washer(8pcs)



M8 Arc Washer(8pcs)



T shape bolts(8pcs)

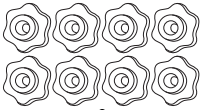

Plastic Nut(8pcs)

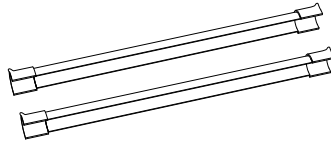

Spare locking sticks(2pcs)

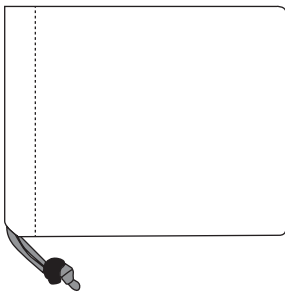

Tool Bag



6mm Hex Key(1pc)

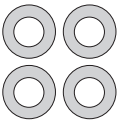

M8 Flat Washer  
(4pcs)



M8 Arc Washer  
(4pcs)

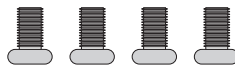

M8x15mm Hex Bolt  
(4pcs)

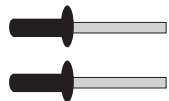

Aluminum Rivet(2pcs)

## Setting up:

1. Release all buckles around the tent.

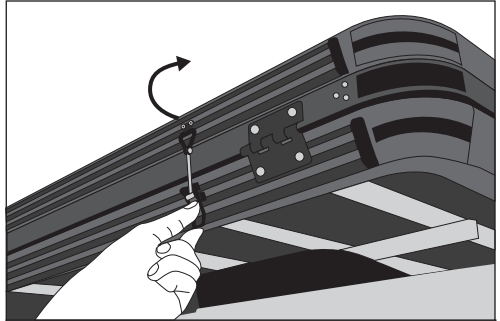

2. Push up the tent from its back side.

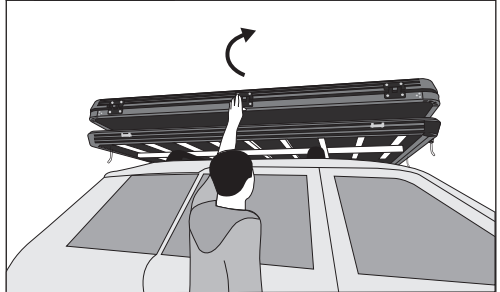

3. Tent will be opened automatically with the gas strut assist.

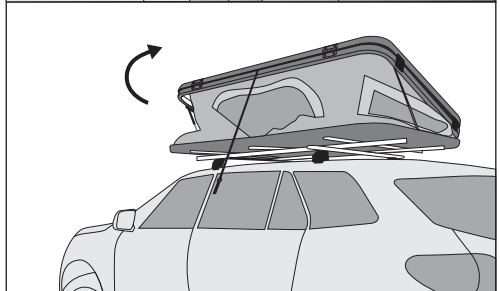

4. Push up the shell from the front side.

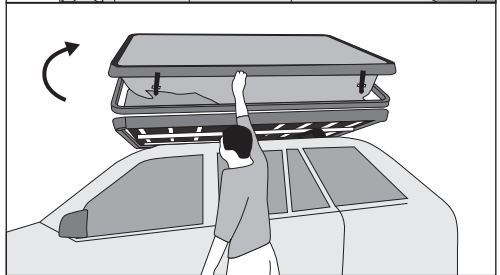

## Setting up:

5. Hang ladder on the frame, then adjust the length.  
(Ensure ladder is stable)

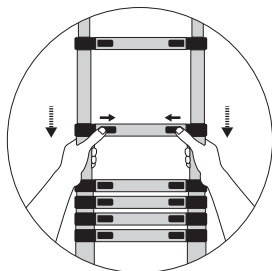

6. The tent is fully set up.





## Folding down:

1. Close all windows. Hook the elastic ropes inside the tent (as P1). Zip up the front door to two thirds position. Tuck shoes bags inside (as P2). Then press down the shell.

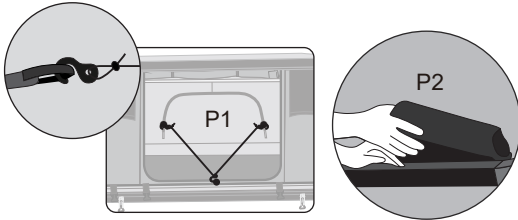

2. Pull down the belt puller on the back side to collapse the tent.

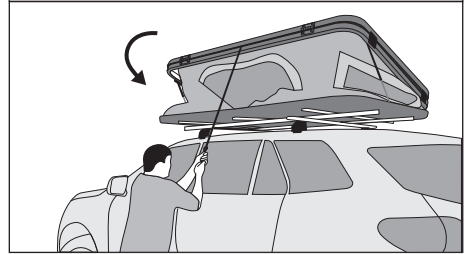

3. Remove then shorten the ladder. Then lock all buckles around the tent.  
(Notice: ensure no fabric expose to outside)

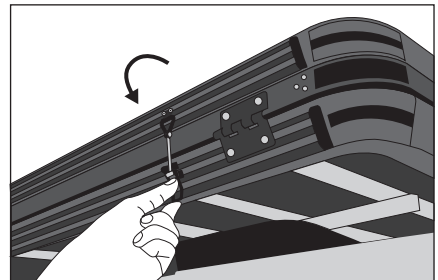
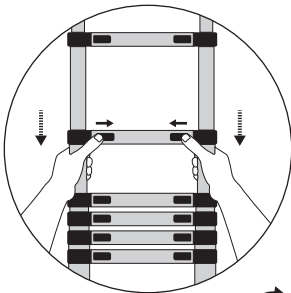

# TROUBLESHOOTING TIPS (IF NEEDED):

Once cylinder rod does not work, pls double check as below.

1. If cylinder rod is covered by any fabric.
2. If there is any air leaking from the cylinder rod. If yes, the cylinder rods need to be replaced. Loosen the screws of the cylinder rod with a screwdriver, and change a new one. pls see pictures below.

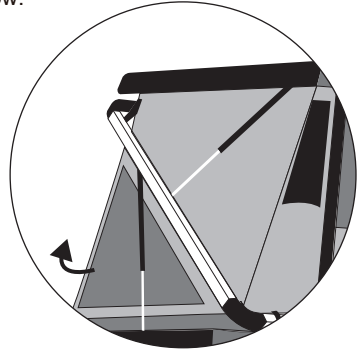

## Usage of the spare locking sticks

Fasten the 2pcs locking sticks to the upper cover gas structs on both sides from windows when setting up the Dix hardtop roof tent. (as P1)

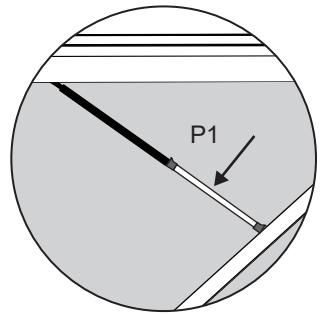
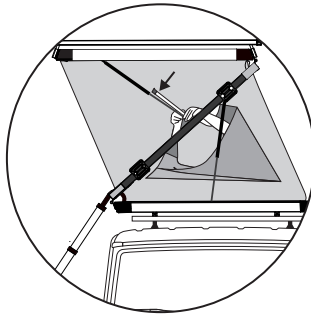

Remove the 2pcs locking sticks before folding down the Dix hardtop roof tent. (as P2)

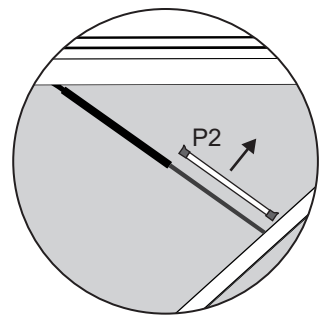
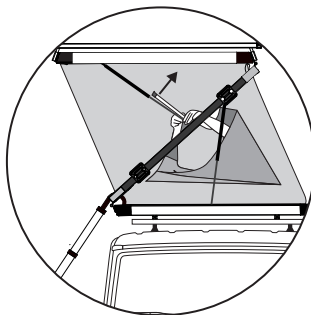

\* This is an emergency solution to avoid the top lid from collapse when gas struct pressure is insufficient especially when combine with the annex. And meanwhile it can extend the service life of gas struct poles.

# Safety Information

---

- We recommend that you DO NOT drive over 70mph ( 110kmh) while using your rooftop tent and that you always adhere to speed limits.
- CHECK at the start of every journey and at regular intervals that your roof top tent is firmly fixed to your roof racks and that all locking straps are securely fastened.
- DO NOT use your roof tent if there is any visible damage to any part of it or its components, instead contact us to see how we can help. This is especially applicable to the locking straps and buckles.
- Understand that secured loads and incorrectly mounted roof bars can come lose during journeys and can cause serious accidents.
- Make sure that you give due consideration to the change in your vehicle height and drive behaviour (side—wind sensitivity, corner and braking behaviour).
- You must always consult your vehicle and roof bar manuals to ensure you are following their advice, these must be always be carried in your vehicle along with your roof tent safety and fitting instructions.
- Do not use bleach, alcohol or ammonia based cleaning liquids on your roof tent otherwise the surface of your roof tent may get damaged
- Please note the following when using your roof tent:
  - The height of your vehicle can increase by up to 90cm (dependant on your roof bars).
  - Beware of low entrances, low hanging branches, etc.
  - Wind noise may be generated when travelling with a roof tent
  - When using an automatic car—wash facility, your roof tent must first be removed.

- In addition to these usage instructions, due consideration should also be given to mounting instructions for your roof bars and the operating instructions of your vehicle.
  - For reasons of fuel economy and the safety of other road users, your roof tent and roof bars should be removed when not in use.
  - For your safety, you should only use tested (e.g. GS—tested) roof bars that are authorised for usage in conjunction with your vehicle.
  - In order to avoid generating excessive lifting forces, your roof tent should be mounted parallel to the line of the road and not at an angle.
- 
- When climbing in and out of your roof tent always use the ladder with due caution and never allow children to use it alone. Make sure the ladder hooks are in good condition, contact us if you need replacements.
  - You must not allow any naked flames in or near your roof tent.

## **Important Information**

---

The manufacturer is not liable for any damage or accident that may occur as a result of non— compliance with these usage instructions, modifications made to parts or the usage of any parts other than the manufacturer' s original parts. The warnings, cautions and instructions in this document can' t cover every possible situation, so it is understood by the operator that common sense and caution must be applied. It is your responsibility to pass these instructions on to any third party who uses this roof tent, including second hand sales.

---

### **Warranty**

***The manufacturer's warranty covers manufacturing faults and lasts one year within regular use. It is only valid if the instructions and recommendations in this document are adhered to and only applies to the first owner. Second hand sales are not covered.***

---